

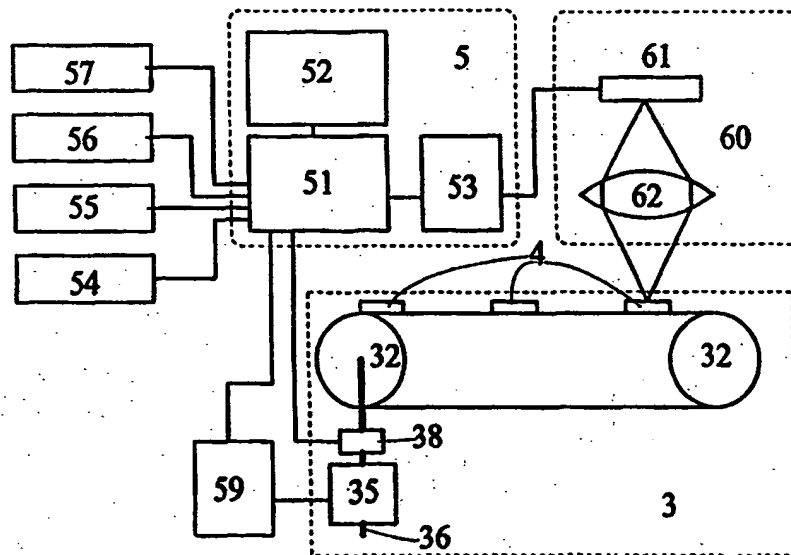

## INTERNATIONAL APPLICATION PUBLISHED UNDER THE PATENT COOPERATION TREATY (PCT)

(51) International Patent Classification <sup>6</sup> : <b>G01N 21/86</b>	<b>A1</b>	(11) International Publication Number: <b>WO 99/41596</b> (43) International Publication Date: 19 August 1999 (19.08.99)
<p>(21) International Application Number: PCT/HU99/00012</p> <p>(22) International Filing Date: 10 February 1999 (10.02.99)</p> <p>(30) Priority Data: P 98 00290 11 February 1998 (11.02.98) HU</p> <p>(71) Applicant (for all designated States except US): 77 ELEKTRONIKA MŰSZERIPARI KFT. [HU/HU]; Fehérvári út 98, H-1115 Budapest (HU).</p> <p>(72) Inventors; and (75) Inventors/Applicants (for US only): SÜMEGI, László [HU/HU]; Bartók Béla út 10-12, H-1111 Budapest (HU). FÖLDVÁRI, Zsolt [HU/HU]; Városház köz 6, H-1031 Budapest (HU).</p> <p>(74) Agent: BOKOR, Tamás; S.B.G. &amp; K. Patent and Law Office, Andrássy út 113, H-1062 Budapest (HU).</p>	<p>(81) Designated States: AL, AM, AT, AU, AZ, BA, BB, BG, BR, BY, CA, CH, CN, CU, CZ, DE, DK, EE, ES, FI, GB, GD, GE, GH, GM, HR, HU, ID, IL, IN, IS, JP, KE, KG, KP, KR, KZ, LC, LK, LR, LS, LT, LU, LV, MD, MG, MK, MN, MW, MX, NO, NZ, PL, PT, RO, RU, SD, SE, SG, SI, SK, SL, TJ, TM, TR, TT, UA, UG, US, UZ, VN, YU, ZW, ARIPO patent (GH, GM, KE, LS, MW, SD, SZ, UG, ZW), Eurasian patent (AM, AZ, BY, KG, KZ, MD, RU, TJ, TM), European patent (AT, BE, CH, CY, DE, DK, ES, FI, FR, GB, GR, IE, IT, LU, MC, NL, PT, SE), OAPI patent (BF, BJ, CF, CG, CI, CM, GA, GN, GW, ML, MR, NE, SN, TD, TG).</p> <p>Published With international search report.</p>	

(54) Title: AUTOMATIC TEST STRIP ANALYSER APPARATUS



## (57) Abstract

The invention relates to an apparatus for analysing urine test strips, comprising a sample holder for the test strips, a transfer mechanism, a light source illuminating the sample placed into the sample holder, and a light intensity detector. The apparatus also comprises a microprocessor for processing the signals of the means for measuring the light intensity and for determining the chemical component. In order to avoid complicating positioning mechanisms for the optical colour measurements, the apparatus is provided with an imaging optical system disposed at a distance from the sample, and depth-independent imaging optics. The functions of the positioning mechanism is substituted with colour and pattern analysis and/or recognition software.

**FOR THE PURPOSES OF INFORMATION ONLY**

Codes used to identify States party to the PCT on the front pages of pamphlets publishing international applications under the PCT.

AL	Albania	ES	Spain	LS	Lesotho	SI	Slovenia
AM	Armenia	FI	Finland	LT	Lithuania	SK	Slovakia
AT	Austria	FR	France	LU	Luxembourg	SN	Senegal
AU	Australia	GA	Gabon	LV	Latvia	SZ	Swaziland
AZ	Azerbaijan	GB	United Kingdom	MC	Monaco	TD	Chad
BA	Bosnia and Herzegovina	GE	Georgia	MD	Republic of Moldova	TG	Togo
BB	Barbados	GH	Ghana	MG	Madagascar	TJ	Tajikistan
BE	Belgium	GN	Guinea	MK	The former Yugoslav Republic of Macedonia	TM	Turkmenistan
BF	Burkina Faso	GR	Greece	ML	Mali	TR	Turkey
BG	Bulgaria	HU	Hungary	MN	Mongolia	TT	Trinidad and Tobago
BJ	Benin	IE	Ireland	MR	Mauritania	UA	Ukraine
BR	Brazil	IL	Israel	MW	Malawi	UG	Uganda
BY	Belarus	IS	Iceland	MX	Mexico	US	United States of America
CA	Canada	IT	Italy	NE	Niger	UZ	Uzbekistan
CF	Central African Republic	JP	Japan	NL	Netherlands	VN	Viet Nam
CG	Congo	KE	Kenya	NO	Norway	YU	Yugoslavia
CH	Switzerland	KG	Kyrgyzstan	NZ	New Zealand	ZW	Zimbabwe
CI	Côte d'Ivoire	KP	Democratic People's Republic of Korea	PL	Poland		
CM	Cameroun	KR	Republic of Korea	PT	Portugal		
CN	China	KZ	Kazakistan	RO	Romania		
CU	Cuba	LC	Saint Lucia	RU	Russian Federation		
CZ	Czech Republic	LI	Liechtenstein	SD	Sudan		
DE	Germany	LK	Sri Lanka	SE	Sweden		
DK	Denmark	LR	Liberia	SG	Singapore		
EE	Estonia						

## Automatic Test Strip Analyser Apparatus

### Technical Field

The object of the invention is an apparatus for analysing a reagent causing a colour  
5 reaction with a component in a sample of matter, in particular a test strip analyser for  
the fast analysis of urine test strips. Such devices comprise a sample holder  
accommodating the reagent entering into chemical reaction with the sample, preferably  
a test strip. The analyser also comprises a reagent transfer mechanism, a light source  
illuminating the sample placed into the sample holder, and means for measuring the  
10 intensity of the light reflected from the sample. In practice, these types of analysers are  
also provided with programmable controller and analyser means, mostly a  
microprocessor. The microprocessor is used for processing the signals of the detector  
and for determining the amount of certain chemical or physical components in the  
urine.

15

### Background Art

Urine analysis is one of the routine diagnostic methods of today's medical science. In  
this method a urine sample of a patient is analysed for certain components, the quantity  
of which is measured, and these data are used to assess the state of the patient's health  
20 or illness. The state of the art urine analysis is made with the help of test strips, which  
contain reagents entering into a chemical or physical reaction with certain well-defined  
components of the urine. The reaction results directly or indirectly in a colour change of  
the test strip. This change of colour is visible with the naked eye, and may be measured  
by instrumental measurement as well. The amount of the sought component is  
25 deductible from the measure of the colour change. Such a reaction will be referred to as  
a colour reaction throughout this description. Further, a colour reaction is meant to  
encompass any sort of physical, chemical or physico-chemical reaction which is  
detectable by optical means.

Earlier, quantitative deductions have been made by a comparison with a colour chart, but later instrumental reading or measurement became common. Today's modern test strips are analysed almost exclusively by instruments, which allow a far more objective measurement than the subjective comparison with the colour chart. In the instrumental measurement, essentially the reflection of the reagent carrier of the test strip is  
5 measured on one or several wavelengths, and the measured reflection value is used to determine the developed colour resulting from the colour reaction on the top surface of the reagent carrier.

Modern test strips analyse several, approx. ten components at the same time. The most  
10 widespread test strips are used to measure blood, ketones, glucose, protein, pH-value, nitrite, bilirubin, urobilinogen, white blood cells, density, etc.

The measurement itself is made by dipping the test strip in the urine sample of the patient, and shaking or wiping off the excess urine. The wetted test strip is placed on a  
15 sample holder, and the instrument performs the measurement on a starting signal or automatically, by measuring the reflection value of the reagent pads of the test strip. The reflection is measured by one or more detectors. Often, one- or two-dimensional CCD-detectors are used. The microprocessor integrated into the instrument calculates the quantity of the sought components, based on the measured reflection values.

20 These measuring instruments are rather expensive devices, because they contain sophisticated optics and mechanics, and complicated electronics. Therefore, only hospitals, laboratories and other institutions can afford to buy them, where large amounts of test strips must be measured regularly. It is expected that the devices should  
25 be able to perform several hundreds of measurements hourly. For this reason, the sophisticated instruments contain a special sample transfer mechanics, which transfer the test strips continuously to the measuring optics, and from there to a waste container.

Measuring large numbers of test strips successively presents serious problems. Firstly,  
30 the usual optical measurements require that the test strips, or at least their test pads are

fixed in a well-defined position during the measurement. Therefore, the known sample holders are provided with some sort of positioning means. But these positioning means are unavoidably contaminated with urine from the test strips, which involves that the successively following test strips will be also contaminated from the positioning means.

5 This cross-contamination of the test strips may seriously distort the later measurements. To avoid this, the positioning means are usually made in a removable manner, and its contaminated parts are regularly cleaned. Especially, the measuring optics must be kept clean, because its cleaning requires special materials, and its removal and re-assembly is also complicated. Therefore, it is sought to avoid any contact between the measuring

10 optics and the test strips.

In some cases, the colour change on the test pads of the test strips is not clearly identifiable, because the discolouring appears in patches or dots. Such a reaction can be analysed only with an analysis of the complete area of the test pad. But the known

15 measurement methods are only capable to measure an average colour of a central region of the pads. It may also happen that a test strip is placed in the device, for which it is not programmed. In this case the colour reaction will be interpreted erroneously, and the device will report false values, if it is not able to distinguish colours, only a change of intensity.

20

Further, it must be considered that the colour reactions with the known test strips progress relatively fast, and disturbing effects may arise both before and after the actual colour reaction. These effects may seriously influence the result of the colour reaction. In order to determine the exact result of the colour reaction, the reflection measurement

25 used to determine the amount of the sought component must be performed in a well-defined time interval. In this case, the quantitative relation between the colour and the amount of the component may be calibrated properly.

One of the known commercially available urine analysis devices is the Clinitek 200

30 urine analyser manufactured by AMES in the United States. With this known device the

colour change of the test strips is measured by photo-detectors, through intermediate fiber optics. The results measured on the test strips is automatically analysed by a built-in microprocessor, and the amounts of the sought components are also calculated. The illuminating light, which is the white light of a halogen bulb, is also guided to the test strips through fiber optics. With this known solution the sensitive optical parts are placed remotely from the test strips, and their contamination is also avoided. But due to the bad imaging properties of the fiber optics, and due to the low efficiency of the input aperture (which decreases even more with growing distance), the test strips must be positioned very precisely relative to the ends of the optical fibres. This is achieved with elastic fixing plates, which press the test strips to the base plate at the measuring position. The test strips are transferred to the measuring position by a toothed conveyor belt, and from the measuring position to waste collecting vessel. A disadvantage of this solution is the continuous contamination of the pressing fixing plates, from the successive test strips, and therefore these must be cleaned regularly. Even so, cross-contamination is not completely excluded.

Another known device is the URISCAN 300 urine analyser made by YEONGDONG in South Korea. This known device applies a CCD-detector as the light detector, and the test strips are illuminated by a light tube producing white light. The test strips are transferred to the measuring optics by a toothed conveyor belt. The amount of the analysed components is calculated from the measured values by a microprocessor, and the values are printed or transferred for further processing to external recipients. It is also a disadvantage of this known device that the transferring mechanics is continuously contaminated by the carried test strips, and the danger of cross-contamination between the test strips is relatively great. Also, the mechanical parts need regular cleaning.

Considering the above, it is an object of the present invention to provide an analyser device with which at least one of the above disadvantages may be eliminated or reduced. Specifically, it has been sought to simplify the transfer mechanics without

sacrificing its throughput capacity (i. e. the number of test strips analysed in a certain time interval), and to minimise the contact between the test strips and the transfer mechanics. At the same time, it was sought to improve the precision of the measurements, and making possible the measurement of uncertain colour reactions.

5 Also, a further aim was the ability to recognise erroneously used test strips. Further, it was an object of the invention to provide a device that is easy and cost-effective to manufacture, from low-cost and readily accessible components, and has an overall simple construction. It was also sought to leave open the possibility to adapt the analyser apparatus for newer test strips in the future, without any structural change.

10

### Summary of the Invention

According to the invention, the above goals are achieved with an apparatus for analysing a reagent causing a colour reaction with a component in a sample of matter, in particular for fast analysis of urine test strips, comprising a sample holder  
15 accommodating the reagent entering into chemical reaction with the sample, preferably the test strip, further comprising a sample transfer mechanism, a light source illuminating the sample placed into the sample holder – preferably a light emitting diode (LED) –, means for measuring the intensity of the light reflected from the sample – preferably a CCD-detector –, further comprising a programmable controller and  
20 analyser means, preferably a microprocessor for processing the signals of the means for measuring the light intensity and for determining the component in the sample.

According to the invention, the apparatus further comprises

A, an imaging optical system disposed at a distance from the sample of matter for imaging the reagent entering into chemical reaction with the sample onto the optical  
25 detector, with means for providing a depth-independent imaging at least in a space segment containing the reagent, and

b, means for colour and/or pattern analysis and/or recognition of an at least one dimensional image detected by the optical detector, and

c, means for determining the result of the colour reaction from the analysed image.

Throughout this description, the terms "pattern recognition" or "image recognition" or "image processing" are considered synonymous terms.

With this solution, significant advantages are achieved compared to the known constructions. Firstly, the transfer mechanism may be simplified to a large extent, because the exact position of the reagent pads (test pads) of the test strips are recognised by the pattern recognition software even if the test strips are slightly displaced or tilted. The simple mechanism is a very important asset, because of the unavoidable and frequent cleaning requirement. This is especially useful with urine analysers. Secondly, the results of the colour reaction can be determined much more exactly with a true colour analysis than with a simple intensity measurement. E. g. the colour recognition program may be programmed to detect automatically the type of the test strip, without the operator having to enter it into the apparatus separately. The analysis of the complete surface of the test pads means that test pads with unusual colouring, e. g. with patches or dots, may be analysed as well. The apparatus according to the invention can be modified to analyse new types of test strips with a different positions of the test pads, without having to modify the imaging hardware. Theoretically, it is also possible to analyse with a urine analyser test strips for completely different measurements, e. g. test strips for blood sugar measurement.

Preferably, the apparatus according to the invention comprises at least three detectors dedicated to measuring different colour components, or alternatively, a detector with multiple segments in its image pixels, the segments being sensitive to different colours. This latter solution requires the most simple optical system. Normally, red, green and blue colour components are measured with the analyser. Practically, the light source emits substantially white light.

With the most preferred embodiment, the imaging optical system of the apparatus according to the invention comprises a telecentric lens system. Such an optical system is capable for ensuring the depth-independent imaging in a finite object space.



Preferably, the means for determining the result of the colour reaction from the analysed image is a microprocessor integrated into the apparatus and/or an external computer connected to the optical detector. In practice, the microprocessor and/or computer is programmed with an pattern and/or colour analysis and/or recognition program. Since modern urine analysers contain microprocessors under any circumstances, which control the various functions of the analyser, it is most simple to perform the pattern and/or colour analysis and/or recognition with this processor. Alternatively, it may be advantageous to employ a dedicated processor for the pattern and/or colour recognition functions, if the control processor would be overloaded with these tasks.

Modern test strips contain several, normally at least ten different test pads for different components to be measured in the sample. Accordingly, it is advantageous if the optical system is provided with means for detecting multiple measuring points adjusted to reagent carriers comprising multiple reagents for determining multiple components in the sample, and the pattern and/or colour analysis and/or recognition program comprises means for distinguishing the different reagents and/or measuring points.

With most test strips, the complete development of the colour reaction takes some time. At the same time, it is expected that the analyser should be able to measure large number of test strips in a relatively short time and therefore it is foreseen that the reagent transfer mechanism comprises a sample receiving location positioned at a distance from the measurement location, and the transfer mechanism comprises means for transferring the sample of matter from the sample receiving location to the measurement location in a predetermined time interval. Preferably, the predetermined time interval is not less than the shortest time necessary for the development of the colour reaction. E.g. in a very simple and attractive embodiment the transfer mechanism comprises an endless conveyor belt, which receives the test strips and transfers them under the measuring optics.

### **Brief Description of Drawings**

By way of example only, an embodiment of the invention will now be described with reference to the accompanying drawing, in which

- 5 Fig. 1A and 1B are schematic side and front views, respectively, of an analyser apparatus according to the invention,
- Fig. 2. is a block diagram illustrating the connection between the internal units of the apparatus according to the invention,
- Fig. 3A and 3B are schemes of the optical system used in variants of the apparatus  
10 according to the invention,
- Fig. 4 is a further embodiment of the optical system, with a telecentric lens,
- Fig. 5 is a schematic figure of the image stored in the evaluating unit,
- Fig. 6 illustrates a first function of the pattern recognition software,
- Fig. 7 illustrates a second function of the pattern recognition software,
- 15 Fig. 8 illustrates a third function of the pattern recognition software,
- Fig. 9 shows the selected area of a test pad on a test strip,
- Fig. 10 illustrates a transformation in the colour recognition software, and
- Fig. 11 illustrates the final analysis of the results of the colour recognition software.

20

### **Best Mode for Carrying out the Invention**

Figs. 1A and 1B illustrate a non-limiting embodiment of the urine analyser apparatus 1, which performs the automatic analysis of the test strips 4. The test strips 4 are known  
25 per se. The apparatus 1 comprises a sample holder – the conveyor 31, as will be explained below - which receives the test strips 4 previously wetted with urine. The test strips 4 are placed on the sample holder by the person handling the apparatus. The sample holder is formed so that several samples, i. e. test strips 4 are held on it simultaneously. The individual test strips 4 are transferred successively to the  
30 measuring optics 6 by the transfer mechanics 3. The measuring optics 6 constitute the

actual measuring unit of the apparatus 1. With this embodiment, the transfer mechanics 3 comprises two parallel running conveyor belts 31, which is held by two pairs of conveyor wheels 32, each pair having a common axle. One of the axles 36 is rotated by the motor 35 via a drive belt 34. Practically, with this embodiment the sample holder is actually constituted by the conveyors 31. In order to avoid eventual gliding of the test strips, the conveyor 31 may be provided with teeth, but in a preferred embodiment, the conveyors 31 have a smooth surface, to facilitate their cleaning.

The test strips 4 progress relatively slowly, during approx. one minute from the sample receiving location 7 to the position which is under the measuring optics 6. During this time the colour reaction takes place, the result of which is determined by the measuring optics 6 and the connected analyser unit (not shown in Figs. 1A and 1B). Moving past the measuring optics 6, at the end of the conveyor 31 the test strips 4 fall into the waste collector 9. The waste collector 9 may be disposed of entirely, when full, or may be emptied to receive more test strips 4.

The functions of the urine analyser apparatus 1 are controlled by the instrument panel 57 on the front of the apparatus. The measured values appear on the display 54, or optionally, are forwarded to other data processing units.

With this embodiment, the measuring optics 6 comprise the light tube 68, and the mirror 67, which latter reflects the image of the test strip 4 into the imaging optical system 60. Instead of the used light tube 68, other means of lighting may be used, e. g. several laser with different colours or an incandescent bulb. However, it is most preferred to use a white light source. The imaging optical system 60 may be realised also without the use of the mirror 67.

In a preferred embodiment, the test strips 4 are laid on the conveyor 31 by hand.

However, with an alternative embodiment, the test strips 4 are put on the conveyor 31

by a sample dispenser 8, which positions the test strips 4 on the conveyor 31 in a proper

position and in the right time, and thereby contributes to the precise analysis of the test pads on the test strips. Alternatively, the sample dispenser 8 positions not the wetted test strips 4, but sterile, dry test strips, and the urine samples are dispensed in exactly portioned drops by the sample dispenser 8 on the test pads of the test strips 4. With this method the contamination of the transfer mechanics by the overall wet test strips is largely prevented. In this manner the cross-contamination of the test strips is also substantially diminished, and the operation of the apparatus must be stopped less often for cleaning.

- 10    Optionally, the apparatus 1 may include a cleaning and sterilising means 10, which continuously cleans the conveyor 31 also during operation of the apparatus, and facilitates almost continuous operation.

Fig. 2 show the block diagram of the internal units of the apparatus 1. The test strips 4 forwarded to the measuring optics 6 by the transfer mechanics 3 are imaged by the lens system 62 onto the detector 61. The output signals of the detector 61 are fed into the evaluating unit 5. The evaluating unit 5 will perform a colour and pattern (image) analysis and/or recognition of the images of the test pads of the test strips 4, and the results are displayed on the display 54, or forwarded to the interface 55 or the printer 56. These latter peripherals may be external devices as well.

The evaluating unit 5 comprises in practice the microprocessor 51, with an attached memory 52 and an A/D converter 53. The memory 52 contains RAM and ROM memory areas. The A/D converter 53 transforms the signals of the 61 detector into a digital signal appropriate for input into the microprocessor 51. Often, the A/D converter is integrated into the CCD-detector. The microprocessor 51 connects to the peripherals, i. e. the display 54, the interface 55, the printer 56 and the instrument panel 57 in a manner known per se. The microprocessor 51 also controls the power supply 59 of the motor 35, and receives the signals of the sensor 38 on the axle 36 of the motor 35.

25

30    Alternatively, the motor 35 may be a stepper motor, which is controlled directly by the

microprocessor 51 through an appropriate driver circuit. In this case the sensor 38 may be omitted.

It must be noted that for image processing (colour and/or pattern analysis and/or  
5 recognition) tasks requiring complicated calculations it may be practical to integrate a dedicated processor into the apparatus, which performs only the image processing, i. e. the actual colour and/or pattern analysis and/or recognition. In this case the microprocessor 51 only controls and co-ordinates the functioning of the separate units, and therefore the microprocessor 51 may be a relatively simple industrial process  
10 control processor.

With the shown embodiment, all the controlling and image processing tasks are performed by the microprocessor 51. The microprocessor 51 receives the digital colour information from the pixels of the detector 61. The resolution, in a practical  
15 embodiment 8 bit, allows for the evaluating program to determine separately the hue, the saturation and the colour intensity of the test pads. This is important, because the final colour of the test pads is a result of several different factors. E. g. the wetting of the pads depends on the time of the dipping into the urine and the usual wiping or shaking off of the excess urine. The intensity of the reflected light is normally  
20 influenced by the wetting, while the emerging colour (hue) itself after the colour reaction is less dependent on the wetting.

The imaging optical system is constructed so that it provides an essentially depth-independent imaging in the space segment where the test strips 4 pass through. By  
25 depth-independent imaging it is understood that the image of the test strips 4 on the detector 61 is practically independent of the position of the test strip 4 along the central optical axis of the imaging optical system 60. The central optical axis is substantially perpendicular to the object plane of the imaging optical system. In the examples shown in Figs. 3A-B and Fig. 4, the image of the test strips 4 is practically unchanged if the  
30 test strips 4 are translated parallel along the co-ordinate axis Z. Of course, this

condition must be fulfilled only in a relatively narrow imaging region T. This is necessary because the test strips tend to bend slightly, due to the wetting and their own weight, and other various reasons. Obviously, this imaging region T must be determined so that standard test strips will remain in the imaging region T even if they are bent slightly, in an extent usual for the test strips.

A few examples of the imaging optical system 60 are shown in Figs 3A, 3B and Fig. 4. Fig. 3A depicts a lens system with an achromatic lens 63. The advantage of this system is the relatively few parts and therefore the potential risk of contamination is also smaller. Its disadvantage is that the light beams at the edges are not perpendicular to the object plane, and the image is more sensitive to the tilting of the object (which may be caused by the bending of the test strip). With the improved embodiment shown in Fig. 3B, the telecentric lens system 62 comprises a Fresnel-lens 64 and a simpler objective lens 66. In this arrangement there are essentially parallel rays arriving from the object, i. e. the test strip 4 are imaged depth-independently by a Fresnel-lens 64, and this image is then imaged further on the detector 61 by the objective lens 66. However, the use of the Fresnel-lens introduces uncertainties into the detected image, by the distorted imaging of some pixels on the CCD. Therefore, in a most preferred embodiment shown in Fig. 4, a telecentric lens system 62 is applied, comprising a telecentric lens 69, an objective lens 66 and a mirror 70, the latter to increase the optical path from the telecentric lens 69 to the objective lens 66. There are more optical elements than with the embodiments of Figs. 3A and 3B, but due to the characteristics of this imaging system, the complete optical system may be positioned further away from the measured test strips, and therefore it is less prone to contamination. At the same time, due to the practically parallel rays, the imaging is almost perfectly depth independent, and in this manner the bending of the test strips does not significantly affect the measurements.

In all three embodiments the in-depth resolution of the imaging is improved by the aperture 65.

In order to allow a colour analysis of the test pads of the test strips 4, the detector 61 is a colour detector, which means that there are several (usually three) detector segments in each image pixel. These detectors are commercially available.

5 The urine analyser apparatus 1 according to the invention operates in the following manner:

After the switching on of the apparatus 1, the motor 35 drives the conveyor 31. The upper, transporting part of the conveyor 31 will move continuously, with an even velocity from the direction of the sample receiving location 7 or the sample dispenser 8  
10 towards the measuring optics 6. In the meanwhile, the operator of the apparatus 1 wets the test strips, e. g. by dipping them in urine, and thereafter puts the test strips 4, one by one, on the conveyor 31 at the sample receiving location 7. The sample receiving location 7 is marked by well-defined visual signs for the operator. The test strips 4 are transported to a position within the imaging region (object space) of the measuring  
15 optics 6. The speed of the conveyor 31 is adjusted so that the colour reaction will take place on the test pads during the time interval while a test strip is wetted, placed on the conveyor, and reach from the sample receiving location 7 to the measuring location.

The microprocessor 51 continuously monitors and stores the signals of the detector 61  
20 of the measuring optics 6. In the shown embodiments the detector 61 is a linear CCD-detector, where the detector segments are positioned along a line. The 51 microprocessor stores a two-dimensional image of the test strips, deducted from the signals of the CCD-detector and the synchronising signals of the sensor 38. The microprocessor 51 is programmed with a pattern- and colour analysis and/or  
25 recognition program, which allows a colour analysis of the test pads on the test strip 4. This pattern- and colour analysis and/or recognition program performs basically the following functions:

- a, recognises that a test strip appeared in the imaging field (object field) of the imaging optics,
- 30 b, thereafter, continuously records and stores the image of the test strip,

- c, with a pattern recognition algorithm, identifies the position and the shape of the test pads on the test strip,
- d, determines the colour (hue and saturation) of the individual test pads,
- e, based on the colour, calculates the component indicated by the individual test pad,
- 5 f, stores the determined amount of the specific component and/or displays the result and/or transfers the data for other data processing units.

The determination of the colour in point d, may be done by determining the average colour of the complete test pad, or the average colour in a central region of the test pad.

10 With this latter method, occasional disturbing effects at the edges of the pads may be largely eliminated. Such an effect may be caused by small liquid droplets attached to the test pad.

Of course, it is possible to assign a different method of analysis to each test pad on a test strip. E. g. the test pads measuring blood content are capable of recognising the haemolised blood cells in the urine. If this is the case, the pads will have a uniform colour. If the blood is not hemolised, the colouring will be dotted. This dotting effect may be detected by the pattern recognition algorithm. If necessary, the size and number of the coloured dots may be determined for the test pad, and diagnostic information

15 may be deduced from a histogram of the dots. In a more simple solution, the non-uniform colouring of the test pad may be detected by the measured variation of the colour values within a single test pad.

20

By deducing true colour information from the test pads, even false colour reactions of the test pads may be determined. These are very difficult to detect by traditional measurement. Such a false colour reaction is the yellow or grey colouring of the test pads for bilirubin and urobilinogen, caused by certain medicines. All these cases may be pre-programmed in the colour recognition program, and therefore these unusual colour reactions may be detected and the results separated intelligently.

25



Example:

The functions of an exemplary pattern- and colour analysis and/or recognition program are explained with reference to Figs. 5 to 11.

5

In a first step, the basic data for the pattern- and colour analysis and/or recognition are extracted from the optical system.

The optical system of the apparatus 1 images an approx. 10 cm long line (perpendicular to the movement direction of the conveyor 31) onto a linear CCD-detector having n colour segments. In a practical embodiment, n = approx. 500. The microprocessor reads the 8 bit digital RGB colour information serially, and performs a linear transformation for all measured data according to the equations

$$15 \quad R_i = A_{iR} * R_{im} + B_{iR} \quad (I a)$$

$$G_i = A_{iG} * G_{im} + B_{iG} \quad (I b)$$

$$B_i = A_{iB} * B_{im} + B_{iB}, \quad (I c)$$

Where  $A_{iR}, A_{iG}, A_{iB}$ , and  $B_{iR}, B_{iG}, B_{iB}$  are constants for the i-th segment of the CCD-  
 20 detector,  $R_{im}, G_{im}, B_{im}$  are the measured RGB values detected by the i-th segment, and  $R_i, G_i, B_i$  are the corrected RGB colour values used in the later processing. The constants  $A_{iR}, A_{iG}, A_{iB}$ , and  $B_{iR}, B_{iG}, B_{iB}$  are determined for each segment with a calibrating measurement using white and grey calibrating test strips, and stored in the memory of the evaluating unit 5 for later use. The transformation of the equations (Ia-c)  
 25 serve to correct the non-uniform imaging caused by uneven illumination and imperfections in the imaging optical system.

In the next step, the pattern analysis and/or recognition program part determines those pixels which should serve as a basis for the colour measurement.

30

Fig. 5 shows the image of the test strips 4 in the form of a pixel image consisting of  $n \times m$  pixels (row  $\times$  column) combined from the pixel information in the memory of the evaluating unit 5. Each  $(R_i, G_i, B_i)$  data define the colour of the  $i$ -th pixel along the Y axis, and the set of the  $(R_1, G_1, B_1)$ - $(R_n, G_n, B_n)$  data represent a column along the Y coordinate of the image. The pixel columns of the image shown in Fig. 5 are measured and calculated successively, as the test strip progresses in the X direction. The pixel information (colour parameters) of the individual pixels are deduced from the signals detected by the detector 61, according to the transformations I a-c above.

The image of Fig. 5 contains approx.  $500 \times 700$  pixels, in the Y and X directions, respectively. The evaluating unit processes the pixel information continuously to find the exact position of the next test strip, and its test pads.

This is done by evaluating the RGB values of the pixels in each row along the X direction (see Fig. 6). These values constitute the  $F_{xi}(RGB)$  function for the  $i$ -th row. The first two intersections of a threshold value  $V$  and the measured  $F_{xi}(RGB)$  function yields an  $X_{i1}$  and an  $X_{i2}$  value for the  $i$ -th row. Thereafter, the edge lines E1 and E2 of the test strip are calculated with a linear regression laid on the points  $(X_{i1}, Y) = (X_{i1}, i)$  and  $(X_{i2}, Y) = (X_{i2}, i)$  for  $i=1 \dots n$ , respectively. Extreme values are discarded, e. g. if they were measured on the following test strip, or if no intersections are found, because no strips are crossed, etc.

At this stage, a further check is performed to ensure that the edge lines E1, E2 are sufficiently steep (ideally parallel to the Y-axis). Also, other similar checks are foreseen to make sure that the test strips have been laid properly on the conveyor, and that no test pads are outside the imaging range of the imaging optics 60.

In order to find the position of the first test pad P1, a test function  $F(\text{test})$  is glided and correlated with the function  $F_y(RGB)$  (see Fig. 7). Here, the test function  $F(\text{test})$  is a 1-0 function with the width corresponding to that of a test pad P, while the function  $F_y(RGB)$  contains the RGB values along a line E5 halfway between the edge lines E1 and E2. The output of the correlation function  $F_{corr}$  is shown in Fig. 8. The first peak

of the correlation function  $F_{corr}$  is deemed to define the y-position  $Y1$  of the centre of the first test pad  $P1$ . The position of the other test pads  $P2-P_k$  are calculated as being in a predetermined distance from the first test pad  $P1$  along the line  $E5$ , or found by a further correlation along the line  $E5$ .

- 5 Having found the central positions of the test pads, the boundaries of the test pads are determined, and the colour values of the pixels corresponding to the test pads are evaluated. These pixels are those within the lines  $E1-E4$  in Fig. 9.

10 In a practical embodiment, in this manner a test pad  $P_k$  of a size approx. 5 mm x 5 mm is transformed to approx. 300-400 pixels, corresponding to 3-4 pixel/mm resolution in one dimension.

In a possible embodiment, the colour analysis and/or recognition program may choose to calculate an average of the RGB values of the pixels measured in a selected test pad, and may simultaneously compare the calculated average R,G,B values with predetermined R, G, B value ranges, thereby deciding if the colour of the test pad corresponds to a certain colour or not. This means practically that the measured values should be included in defined segments of a three-dimensional colour (hue, saturation and intensity) field. However, it has been found that it is better to eliminate the intensity information of the colour, and to examine the hue and saturation of the test pads only.

15  
20

Therefore, the three colour co-ordinates are transformed into a two-dimensional data set, according to the following equations:

25 
$$A = 0.866 * (B - G) / (R + B + G) \quad (II a)$$

$$B = (R - 0.5 * (B + G)) / (R + B + G) \quad (II b)$$

This transformation yields a two-dimensional plane  $P(A,B)$  in the three-dimensional RGB field, very similar to a colour triangle. This is shown in Fig. 10.

We have found that the A and B values calculated in this manner and corresponding to well-defined amounts of the various components of the urine, measured by the appropriate test pads, constitute a well-defined area in the P(A,B) plane. These areas are identified by calibrating measurements. Thereafter, the quantitative analysis of a test pad is made by comparing the position of the measured sample with the positions of the calibrated samples in the P(A,B) plane. This is illustrated in Fig. 11, which shows various sample points M in the transformed colour plane P(A,B). The sample points M correspond to different values of glucose measured in the urine, ranging from negative (corresponding to zero or below threshold) to +++ (corresponding to approx. 1000 mg/100cm<sup>3</sup>). As seen in Fig. 11, all sample points M are within a crescent-shaped field G, with the different values of the calibrating sample points M concentrated in well-defined regions of the field G.

As an alternative transformation requiring less calculation, one of the three colour coordinates may be omitted completely. However, such a transformation can not be used reliably with some test strips.

Further, the apparatus may be programmed to measure and store the colour of the urine sample itself on a neutral white test pad. Such information is also frequently requested by the doctors using the results of the urine analysis.

Further, the apparatus may be programmed to perform a colour compensation of the test pads on the basis of the colour measurement of the urine. Many test strips contain a so-called control pad for this purpose. The colour compensation may be done most easily by simply subtracting the RGB values measured on the neutral, non-reacting urine sample from the other RGB values measured on the reacting test pads. This subtraction or other method of colour compensation may be done both before and after the colour transformations from the RGB field into the P(A,B) plane.

The invention is not limited to the presented embodiments, but other variations are equally well applicable for those skilled in the art. The position and the colour of the test pads may be found with other algorithms as well, e. g. the x co-ordinates of the test pads can also be found with the correlation method using a pad-wide test function. The

5 correcting transformation of the CCD-pixel's output (equations I a-c), being a linear transformation, may be performed only once, on an average colour measured across the test strip in the X direction, instead of performing it on every pixel in the row. Also, instead of a conveyor belt, the transfer mechanics may comprise a rotating disk or any other mechanism providing an alternating or translating movement for the test strips.

10 Instead of a linear CCD-detector a two-dimensional CCD matrix is also applicable, similar to those used in video cameras.

- 20 -

## Claims:

1. Apparatus for analysing a reagent causing a colour reaction with a component in a sample of matter, in particular for fast analysing of urine test strips, comprising a sample holder accommodating the reagent entering into chemical reaction with the sample, preferably the test strip, further comprising a sample transfer mechanism, a light source illuminating the sample placed into the sample holder, an optical detector for measuring the intensity of the light reflected from the sample – preferably a CCD-detector –, further comprising a programmable controller and analyser means, preferably a microprocessor for processing the signals of the means for measuring the light intensity and for determining the component, characterised by further comprising
- a, an imaging optical system disposed at a distance from the sample of matter for imaging the reagent entering into chemical or physical reaction with the sample onto the optical detector, with means for providing a depth-independent imaging at least in a space segment containing the sample and the reagent, and
  - b, means for colour and pattern analysis and/or recognition of an at least one dimensional image detected by the optical detector, and
  - c, means for determining the result of the colour reaction from the analysed image.
2. The apparatus according to claim 1, characterised by comprising at least three optical detectors dedicated to measuring different colour components.
3. The apparatus according to claim 1, wherein the optical detector comprises multiple segments in an image pixel, the segments being sensitive to different colours.
4. The apparatus according to any one of the claims 1 to 3, characterised by comprising a light source emitting substantially white light.
5. The apparatus according to any one of the claims 1 to 4, characterised by that the imaging optical system comprises a telecentric lens system.

6. The apparatus according to any one of the claims 1 to 4, characterised by that the means for determining the result of the colour reaction from the analysed image is a microprocessor integrated into the apparatus and/or an external computer connected to  
5 the optical detector.

7. The apparatus according to claim 6, wherein the microprocessor and/or computer is programmed with an pattern and/or colour analysis and/or recognition program.

10 8. The apparatus according to claim 7, characterised by that the optical system is provided with means for detecting multiple measuring points adjusted to reagent carriers comprising multiple reagents for determining multiple components in the sample, and the pattern and/or colour analysis and/or recognition program comprises means for distinguishing the different reagents and/or measuring points.

15 9. The apparatus according to any one of the claims 1 to 8, characterised by that the sample transfer mechanism comprises a sample receiving location positioned at a distance from the measurement location, and the transfer mechanism comprises means for transferring the sample of matter from the sample receiving location to the  
20 measurement location in a predetermined time interval.

10. The apparatus according to claim 9, wherein the predetermined time interval is not less than the shortest time necessary for the development of the colour reaction.

25 11. The apparatus according to any one of the claims 1 to 10, characterised by that the transfer mechanism comprises an endless conveyor belt.

12. The apparatus according to any one of the claims 1 to 11, characterised by further comprising means for cleaning and sterilising at least parts of the transfer mechanism.

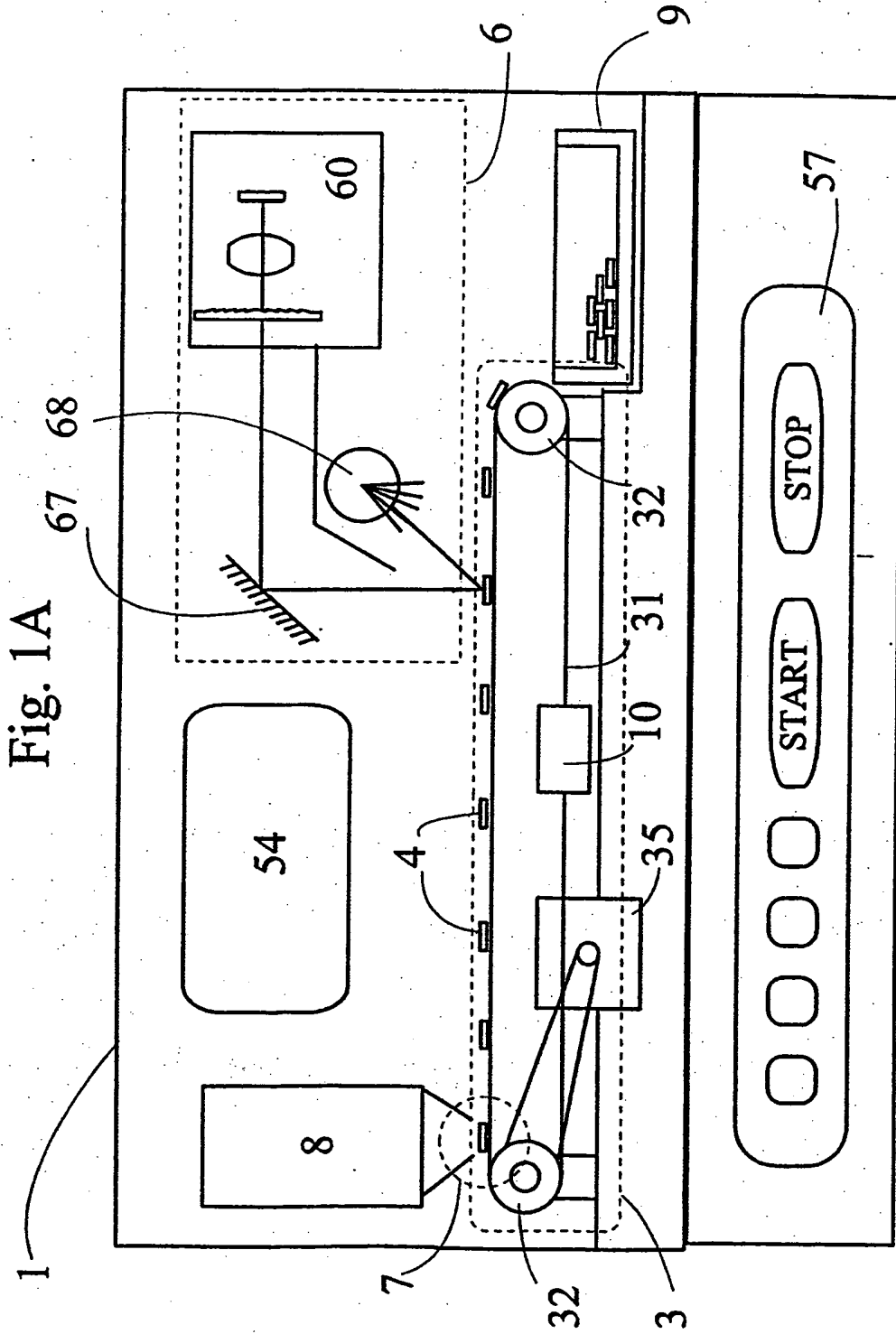



Fig. 1B

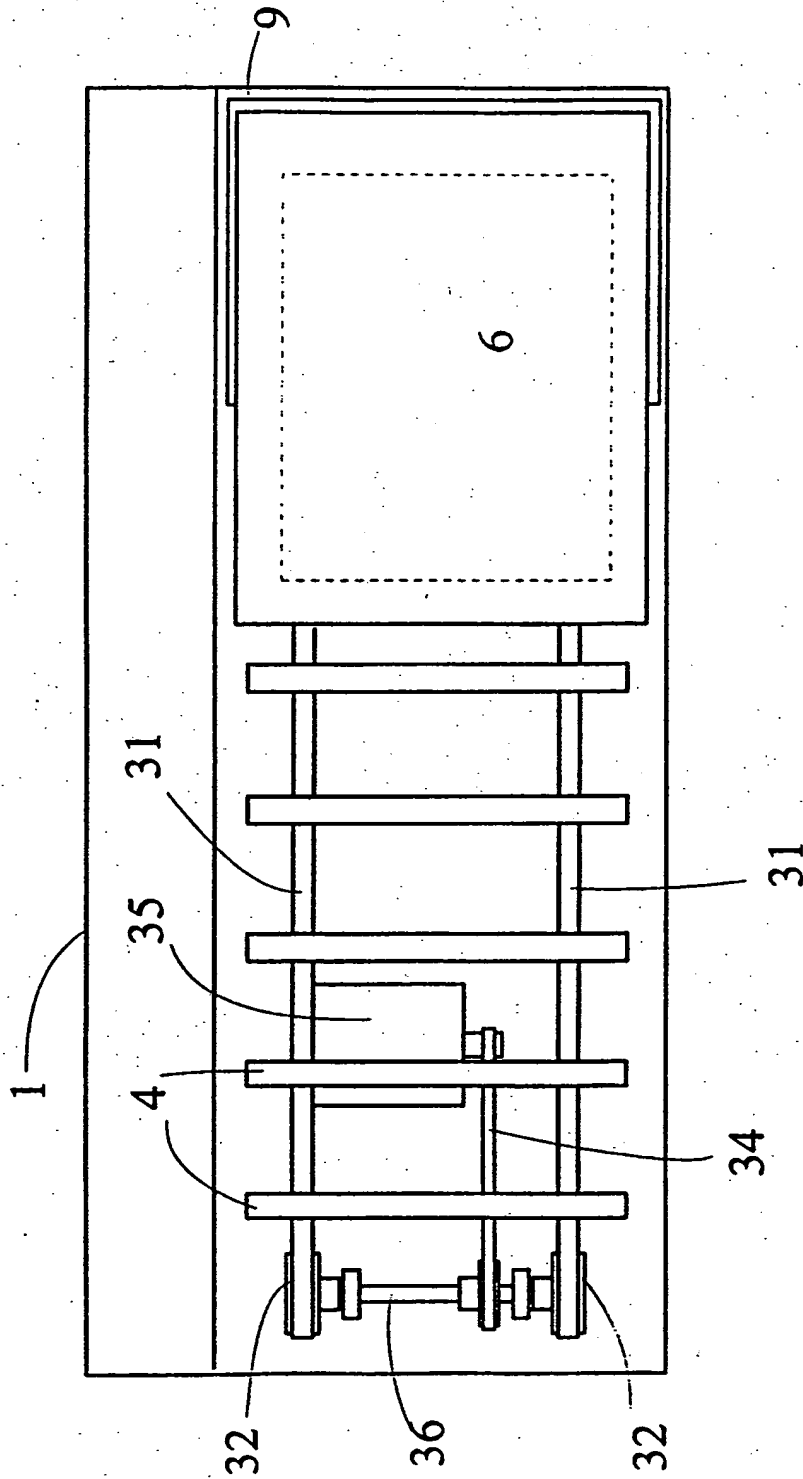

Fig. 2

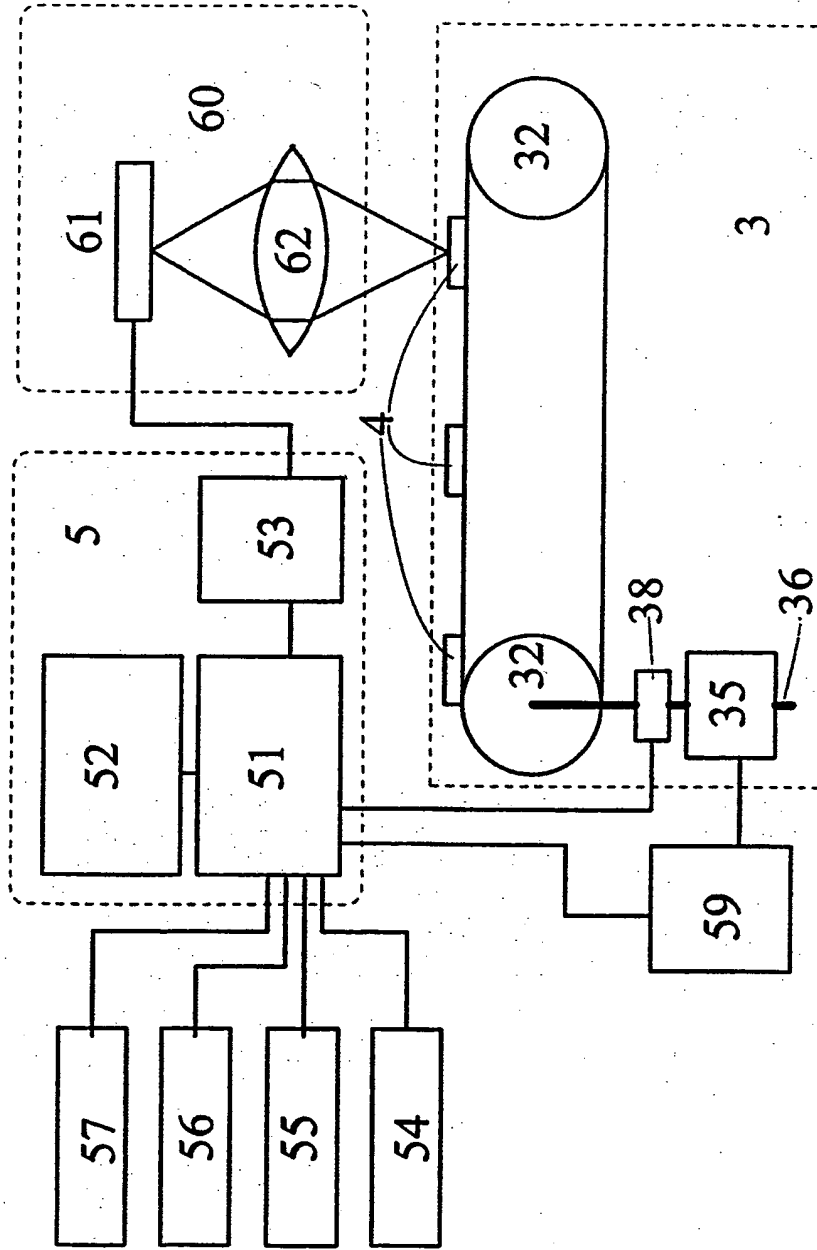

Fig. 3B

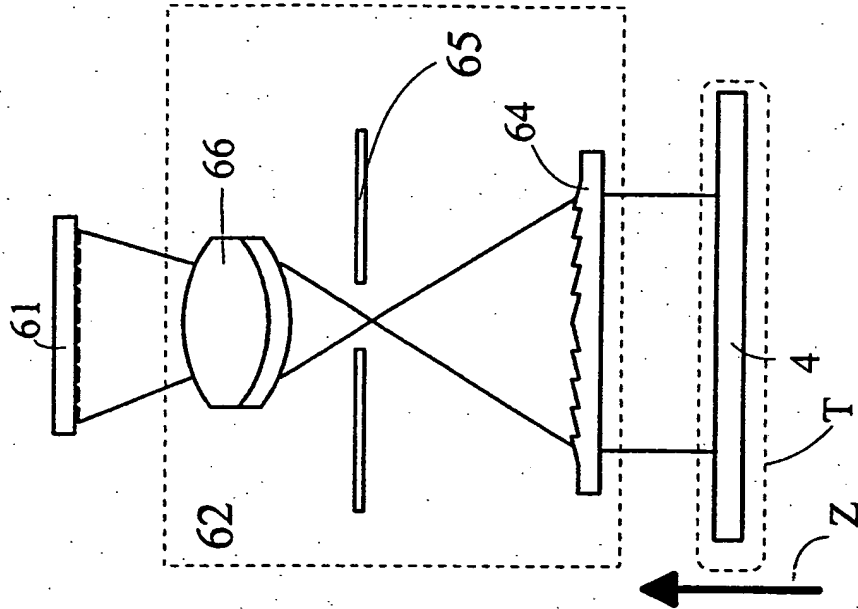
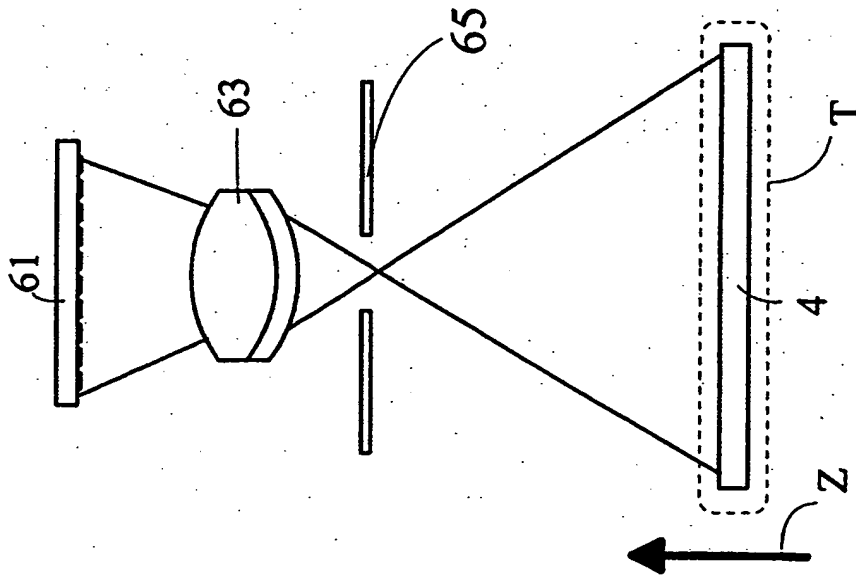
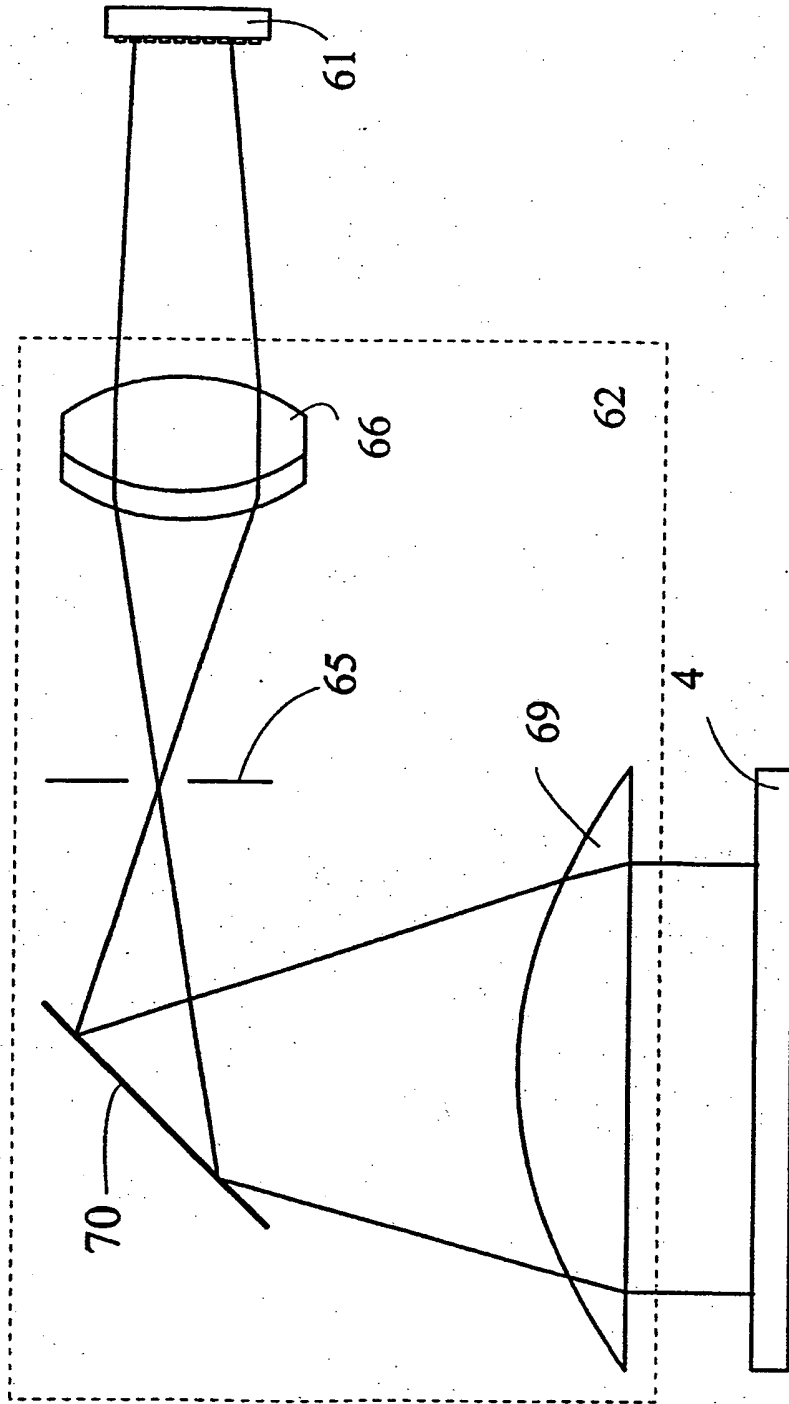

Fig. 3A



5/7

Fig. 4



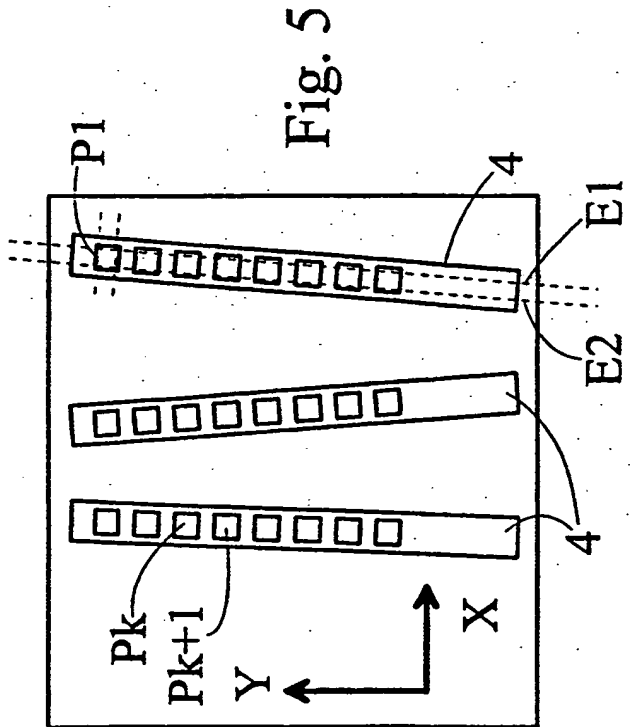
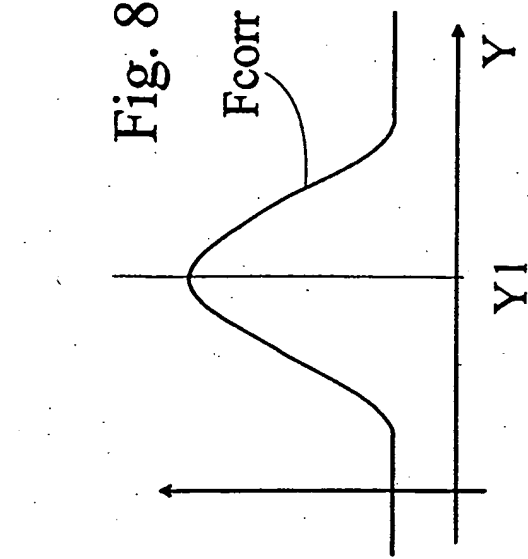
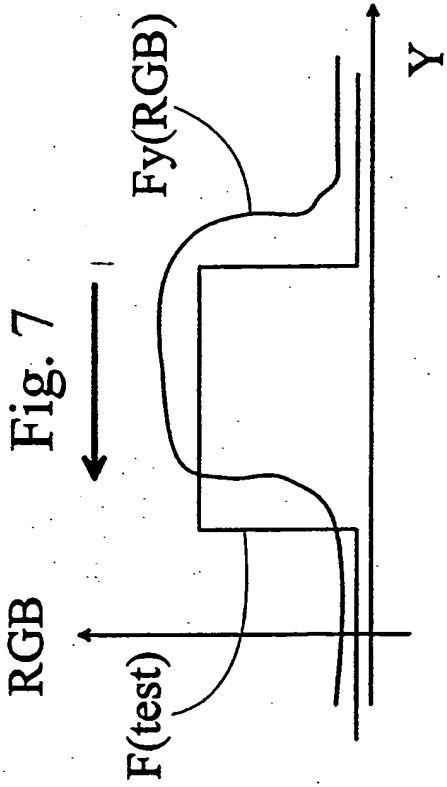
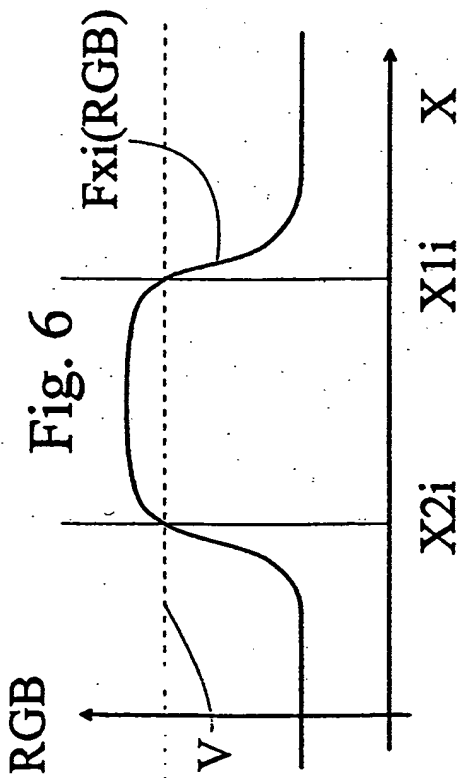

Fig. 9

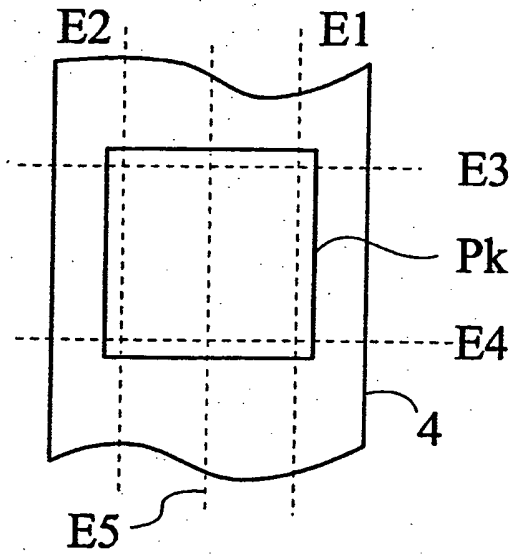

Fig. 10

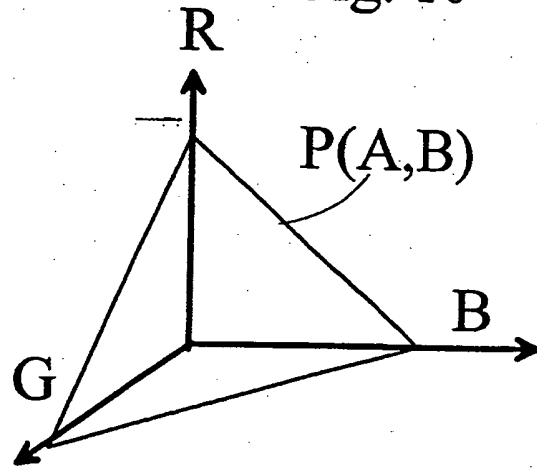
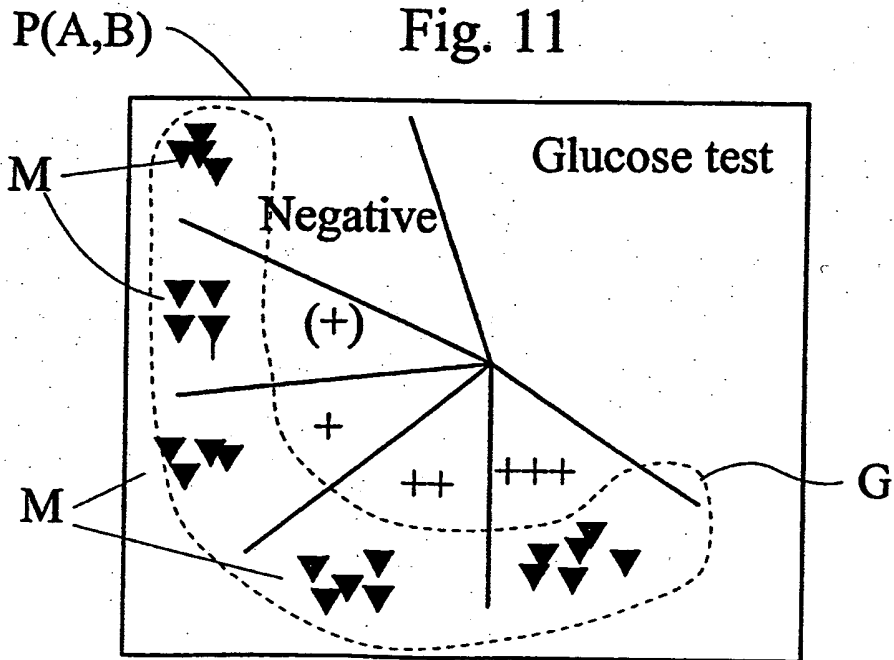

Fig. 11



# INTERNATIONAL SEARCH REPORT

International Application No

PCT/HU 99/00012

**A. CLASSIFICATION OF SUBJECT MATTER**  
 IPC 6 G01N21/86

According to International Patent Classification (IPC) or to both national classification and IPC

**B. FIELDS SEARCHED**

Minimum documentation searched (classification system followed by classification symbols)  
 IPC 6 G01N

Documentation searched other than minimum documentation to the extent that such documents are included in the fields searched

Electronic data base consulted during the international search (name of data base and, where practical, search terms used)

**C. DOCUMENTS CONSIDERED TO BE RELEVANT**

Category *	Citation of document, with indication, where appropriate, of the relevant passages	Relevant to claim No.
Y	EP 0 646 784 A (MILES) 5 April 1995  see abstract see page 4, line 40 - line 52 see page 6, line 40 - line 52 see page 7, line 43 - line 53 see figures 1-3	1,2,4-9, 11
Y	US 5 523 583 A (CHOATE) 4 June 1996  see column 1, paragraph 1 see column 1, line 35 - line 39 see column 1, line 46 - line 50 see column 3, line 7 - line 18 see column 5, line 39 - line 50 see column 5, last paragraph - column 6, line 4	1,2,4-9, 11

Further documents are listed in the continuation of box C.

Patent family members are listed in annex.

\* Special categories of cited documents :

- "A" document defining the general state of the art which is not considered to be of particular relevance
- "E" earlier document but published on or after the international filing date
- "L" document which may throw doubts on priority claim(s) or which is cited to establish the publication date of another citation or other special reason (as specified)
- "O" document referring to an oral disclosure, use, exhibition or other means
- "P" document published prior to the international filing date but later than the priority date claimed

- "T" later document published after the international filing date or priority date and not in conflict with the application but cited to understand the principle or theory underlying the invention
- "X" document of particular relevance; the claimed invention cannot be considered novel or cannot be considered to involve an inventive step when the document is taken alone
- "Y" document of particular relevance; the claimed invention cannot be considered to involve an inventive step when the document is combined with one or more other such documents, such combination being obvious to a person skilled in the art.
- "&" document member of the same patent family

Date of the actual completion of the international search

21 May 1999

Date of mailing of the international search report

01/06/1999

Name and mailing address of the ISA

European Patent Office, P.B. 5818 Patentlaan 2  
 NL - 2280 HV Rijswijk  
 Tel. (+31-70) 340-2040, Tx. 31 651 epo nl,  
 Fax (+31-70) 340-3016

Authorized officer

Thomas, R.M.

# INTERNATIONAL SEARCH REPORT

International Application No  
PCT/HU 99/00012

C.(Continuation) DOCUMENTS CONSIDERED TO BE RELEVANT		
Category *	Citation of document, with indication, where appropriate, of the relevant passages	Relevant to claim No.
A	GB 2 221 297 A (PA CONSULTING SERVICES) 31 January 1990 see page 8, line 22 - line 31	1,5
A	US 5 699 794 A (FLECK) 23 December 1997  see column 5, paragraph 1. see column 6, line 46 - line 63 see column 7, line 6 - line 14 see column 7, line 32 - line 39 see column 10, line 13 - line 20 see column 11, line 24 - line 46 see figures 1,2,11-14 -----	1,6,7,9, 11



**INTERNATIONAL SEARCH REPORT -**

Information on patent family members

International Application No

PCT/HU 99/00012

Patent document cited in search report		Publication date	Patent family member(s)	Publication date
EP 0646784	A	05-04-1995	US 5408535 A	18-04-1995
			AU 661945 B	10-08-1995
			AU 7032794 A	13-04-1995
			CA 2130970 A	08-03-1995
			JP 7190940 A	28-07-1995
US 5523583	A	04-06-1996	JP 8285537 A	01-11-1996
GB 2221297	A	31-01-1990	NONE	
US 5699794	A	23-12-1997	NONE	

**THIS PAGE BLANK (USPTO)**